



OWNER'S MANUAL

OX4000 Series

Installation and Service Manual

INTRODUCTION
SPECIFICATIONS
UNPACKING
MOUNTING
ELECTRICAL
OPERATION
MAINTENANCE
REPLACEMENT PARTS
TROUBLESHOOTING

IMPORTANT

MANUAL CONTAINS PRECAUTIONARY STATEMENTS RELATING TO WORKER SAFETY. READ AND SAVE THIS MANUAL COMPLETELY AND COMPLY AS DIRECTED. ALL THE POTENTIAL HAZARDS OF DUST AND MIST CONTROL SYSTEMS AND EQUIPMENT ARE IMPOSSIBLE TO LIST; THEREFORE, OBTAIN THE SERVICES OF A PROFESSIONAL INSTALLER. A FIRE PROTECTION EXPERT SHOULD BE OBTAINED IN THE EVENT THE PRODUCT IS INTENDED FOR USE THAT PRESENTS A POTENTIAL RISK OF FIRE OR FIRE PROPAGATION. REFER TO APPROPRIATE AUTHORITIES, AND DISCUSS YOUR INTENDED USE WITH YOUR LOCAL DISTRIBUTOR OR BLUE OX. WORKERS HANDLING EQUIPMENT OR SYSTEMS SHOULD BE INSTRUCTED TO CONDUCT THEMSELVES IN A SAFE MANNER.

RETAIN THESE INSTRUCTIONS FOR FUTURE REFERENCE.

SPECIFICATIONS OF THE BLUE OX4000

Cabinet	16 GA Cold-rolled Steel
Finish	Circuit Blue" Polyester Powder Coating (Brown and black available)
Power	2 H.P. – 208-230 VAC / 460 VAC - 6.0-5.8/ 2.9 AMPS @1248-1334 Watts
Capacity	Max 4000 CFM
Motor	2 H.P. TEFCBB Belt Driven @72 dBA.
Speed	Single Speed
Blower	Centrifugal Forward Curve
Grille	Four way individually adjustable blades
Bag Filter Size	24 x 24 x 22" 8 pocket bag
Pre-filter	Standard 24" X 24" X 4" Pleated <i>Optional 24" X 24" X 4" Washable aluminum pre-filter</i>
Options	Silencer – Reduces noise by 6-8 Dbs. With Upgraded Louver Silencer – Reduces noise by 10-12 Dbs. With Non-Directional Grill Magnehelic Pressure Gage (shows when to change filters) Strut Channel – 28", 52" or 76" Strut Channel, Depending on Model. Touch Up Paint – "Circuit Blue" Paint Spray Can Drain Plug – Oil / Mist Drain via Hose Barb Fitting
Warranty	Three years on all parts, does not include filters

Dimensions/
Weight

Model	Dimensions	Shipping Weight	Hanging Weight
OX4000-1x2	72"L x 24"W x 50" H	385 lbs.	360 lbs.
OX4000-1x2-WA	108"L x 24"W x 52" H	590 lbs.	560 lbs.
OX4000-1x3	72"L x 24"W x 74" H	490 lbs.	455 lbs.
OX4000-1x3-WA	108 L x 24"W x 76" H	675 lbs.	650 lbs.
OX4000-2x1	72"L x 48"W x 26" H	435 lbs.	400 lbs.
OX4000-2x2	72" L x 48"W x 50" H	630 lbs.	600 lbs.
OX4000-2x3	72"L x 48"W x 74" H	830 lbs.	790 lbs.
OX4000-3x1	72"L x 72"W x 26" H	585 lbs.	550 lbs.

SAFETY RULES

Follow all electrical and safety codes as well as the National Electrical Code (NEC), National Fire Protection Association (NFPA), and the Occupational Safety and Health Act (OSHA). Only qualified personnel should perform all electrical connections and wiring.

National Fire Protection Association (NFPA) standards require specific duct design and dust collector configuration when collecting potentially reactive metal dusts, such as aluminum, magnesium, and other materials. NFPA also covers other dusts such as grain and plastics, etc. A guideline for determining the precautions to be taken can be found in NFPA 497. Other NFPA standards may apply to your specific application. Consult current NFPA standards, available for NFPA, 1 Batterymarch Park, Quincy, MA, 02269, 800-344-3555, for applicable safeguards which may be required for the Installation, Operation, and Service of this product.

Additional references are the Uniform Building Code and the Uniform Mechanical Code.

WARNING

1. Avoid mixing combustible materials such as (but not limited to) buffing lint, paper / wood dust, aluminum or magnesium with dust generated from the grinding of ferrous materials. This creates a potential for fire due to the mixing of sparks and combustible materials.
2. Under no conditions should the machine operator be allowed to put lit cigarettes or any burning object into this or any dust/mist control system.
3. Installation of this unit in applications where there is a chance for heated and/or flammable materials to enter the unit should be evaluated to determine if a fire protection/extinguishing system should be installed. Federal, state or local codes, a required by organizations such as NFPA and Factory Mutual Insurance or your insurance carrier may require such a system. Air Cleaning Specialists, Inc. can offer basic guidelines for such an installation; however, **final installation design is the responsibility of the filtration unit Owner/User.**
4. Explosion relief vents are required on some applications. Consult with an insurance underwriter or an NFPA manual to determine proper vent size ratio. Dust or mist collectors must be located outdoors unless otherwise indicated by NFPA standards. Dust and mist collectors **DO NOT CONTAIN EXPLOSION RELIEF VENTS** as shipped from the factory and must be field installed per NFPA standards.

**ALWAYS USE BLUE OX REPLACEMENT FILTERS & PARTS TO MAINTAIN WARRANTY.
TO ORDER REPLACEMENT PARTS CALL 866-455-2135 OR EMAIL info@aircleaningspecialists.com.**

BLUE OX LIMITED WARRANTY

Air Cleaning Specialists, Inc. warrants all products sold, only to purchasers for use in business or for resale, against defects in workmanship or materials under normal use for three years after date of purchase from Air Cleaning Specialists, Inc. This three year warranty does include standard warranties from purchased parts such as blowers, motors, valves, etc. All purchased items will fall under the manufacturers' standard warranty. Any part which is determined to be defective in material or workmanship and returned to Air Cleaning Specialists, Inc. or authorized service facility, as Air Cleaning Specialists, Inc. designates, shipping cost prepaid, will be, as the exclusive remedy, repaired or replaced, at Air Cleaning Specialists, Inc. option. Any liability for consequential and incidental damage is expressly disclaimed. Air Cleaning Specialists, Inc. liability, in all events, is limited to and shall not exceed, the purchase price paid. Title and risk of loss pass to buyer on delivery to the common carrier. If product is damaged in transit, recipient must file claim with carrier. Air Cleaning Specialists, Inc. will make a good faith effort for prompt correction or other adjustments with respect to any product that proves to be defective within the warranty period.

DISCLAIMER

Although instructions and recommendations are included for installation of your mist or dust collector equipment, the manufacturer does not assume responsibility for the installation of this equipment nor shall be held liable for direct or consequential damages resulting from improper methods, structural failure or inadequate supports.

SAFETY

READ AND SAVE THIS MANUAL COMPLETELY AND COMPLY AS DIRECTED. THIS MANUAL CONTAINS PRECAUTIONARY STATEMENTS RELATING TO WORKER SAFETY. WORKERS HANDLING EQUIPMENT OR SYSTEMS SHOULD BE INSTRUCTED TO CONDUCT THEMSELVES IN A SAFE MANNER. ALL THE POTENTIAL HAZARD OF DUST AND MIST CONTROL SYSTEMS AND EQUIPMENT ARE IMPOSSIBLE TO LIST. THEREFORE, OBTAIN THE SERVICES OF A PROFESSIONAL INSTALLER. A FIRE PROTECTION EXPERT SHOULD BE OBTAINED IN THE EVENT THE PRODUCT IS INTENDED FOR USES, WHICH PRESENT A POTENTIAL RISK OF FIRE OR FIRE PROPAGATION. REFER TO APPROPRIATE AUTHORITIES, AND DISCUSS YOUR INTENDED USE WITH AIR CLEANING SPECIALISTS, INC.

Initial Inspection

If your new BLUE OX units were shipped in by truck you should inspect the carton for damages or possible shortages. If there are any signs of possible shipping damages, unpack the units and make a note of the shortage or damage on the freight bill before signing it. If the carton is opened at a later time and there is damage to the unit, you should file a concealed damage claim with the delivery carrier. They are responsible for any damages in shipment or shortages that were actually shipped.

Installing Your New BLUE OX Units

All installations must meet all electrical or mechanical building codes that may apply in your particular area. If there are no local requirements, you should follow the National requirements. If the optional Drain Plug was installed in your unit, you can connect an appropriate 3/8" I.D. rubber hose for oil/mist routing.

All chains, hooks, bolts or other items used in the installation must be at least strong enough to support FOUR times the Hanging Weight of each unit. Unit weights are shown above in the Dimension/Weight chart.

Methods for Mounting your OX4000 unit

There are many different ways to install your units. The most common method of installing the units is to support them from the ceiling structure with four chains. Strut channel is then placed underneath the Blue OX Unit and then hung with appropriate steel chains and Q-Links.

Some units can qualify for Eye-Bolt mounting, which utilized top side mounted eye bolts for simple installations. Some unit weights exceed safe hang weights for the eye-bolts; please consult our experts to find the best mounting options for your unit.

The top end of the chains must be secured to the ceiling structure in a safe and acceptable manner and should be able to support FOUR (4) times the weight of the unit. Unistrut or equal may be utilized.

The next page includes sketches indicating possible methods of mounting your OX4000 cabinets. Please ensure all installations are secure and meet all local, state, and federal codes. Be sure your unit is connected to the proper voltage and is protected by correct size fuses or breakers.

OX4000 Installation, Mounting Options

Mounting Strut Channel

Due to the Multi-Unit weights and dimensions, we advise to only hang these units with underneath strut support, with chain, and eye-bolts, mounted to the ceiling.

The drawing below shows the most common method to hang these units.

All hardware should be able to support 4 (4) times the weight of the unit.

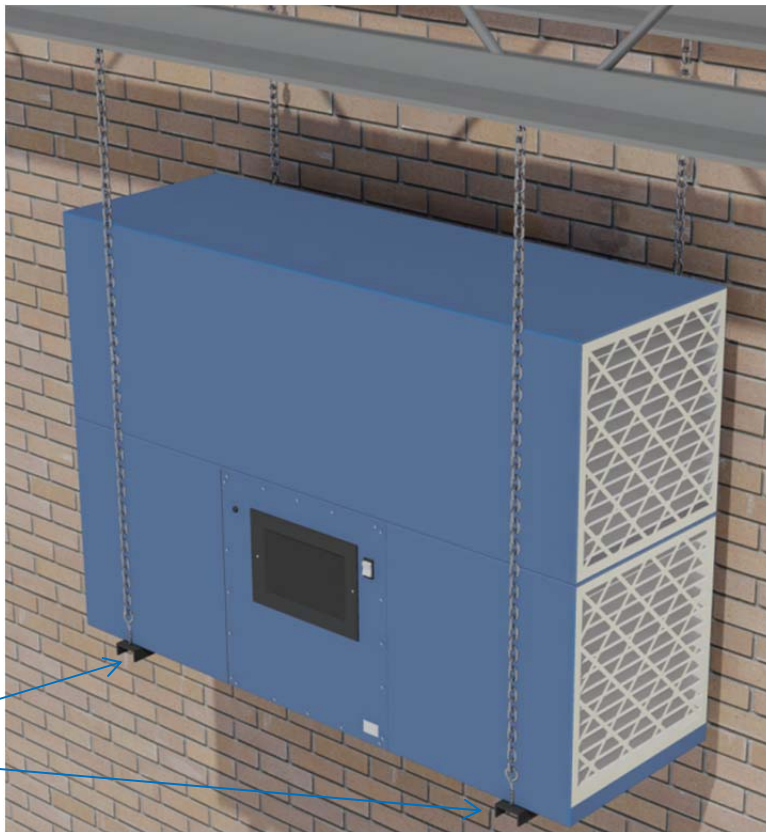

Strut Channel Installed to Ceiling Truss

Strut Channel

BLUE OX products are designed to improve your environment. OX4000 series collects dust, smoke, oil mist, oil smoke, and other atmospheric pollutants in industrial plants, shops, schools, and factories with high efficiency, 2 or 3 stage filtration. It is a complete air filter packaged unit that can be installed easily and used as a free hanging air filter unit to clean the ambient pollutants, smoke and haze.

The OX4000 Series consists of a 4" pleated pre-filter that traps dust and larger particles. The second stage, micro-glass multi-pocket bag filter has 98% arrestance and either 65 or 95% efficiency (depending on the application) on the atmospheric dust spot test, removing smoke and other submicron size particles from the air. Changing out the filters is easy as it requires no tools. The 4" pre-filter pulls from the unit and can be replaced. The main filter is located directly behind the 4" pre-filter and pulls out also. For light odors, there is an optional 2" 50% bypass charcoal after-filter available.

MOTOR

The OX4000 is a belt driven unit. The motor must be protected externally via breaker and disconnect switch.

OPERATION

Do not operate your unit(s) without filter for more than a few minutes at a time.

MAGNEHELIC PRESSURE GAGE OPTION

This is an option to help determine when to change the filters. As the bags fill with contaminants, the needle on the gage will rise. We recommend changing the bags between 1.25 – 1.50 above the reading with clean filters. It is normal to change the pleated twice (or more) as much as the inside bag filter. After the pleated has been change and there is no longer a drop in pressure, then it is time to change main filter. The reading may vary depending upon the contaminants. Please consult your Sales Engineer for further information.

FILTERS

All units are equipped with replaceable type media filters. In some cases, where contaminants being picked up are dry, it is possible to blow the pre-filters and reuse them. Filters are available in a number of different degrees of efficiencies. The filters in your new OX4000 unit have been selected by your representative to best collect your particular type of contaminant.

Media type filters actually become more efficient as they load with contamination. However, as the filters load up, the air flow volume will decrease and eventually will reach a point where they must be replaced to restore the original air flow. Changing the filters in your new OX4000 air cleaner is really easy. Old filters are simply pulled out of the entrance end of the unit and new filters are installed. No tools are required. Turning the unit on when installing new filters will help to pull them into place.

GENERAL NOTE: CLEANING AND INSPECTION OF CABINET

After the dirty components have been removed, inspect the cabinet interior. Remove foreign material, wipe interior, and clean all filter seating surfaces.

When installing new filters the opening in the bag filter and the pre-filter should be in a vertical position. Be sure the cloth part of the bag does not bunch up between the bag header and the angle iron filter stops on the cabinet. The pre-filter should be installed with the wire mesh to the inside of the unit. Replacement filters can be supplied by your representative.

LOUVERS

Four way lovers are provided on all units to permit you to direct the discharge air away form pilot lights on heaters and to help you obtain the best air flow pattern for maximum cleaning.

PARTS

ALWAYS USE BLUE OX REPLACEMENT FILTERS & PARTS TO MAINTAIN WARRANTY.

TO ORDER REPLACEMENTS PARTS: CALL 866-455-2135 | EMAIL info@aircleaningspecialists.com

11088 Gravois Industrial Court, St. Louis, MO 63128

OX4000 Wiring Diagram

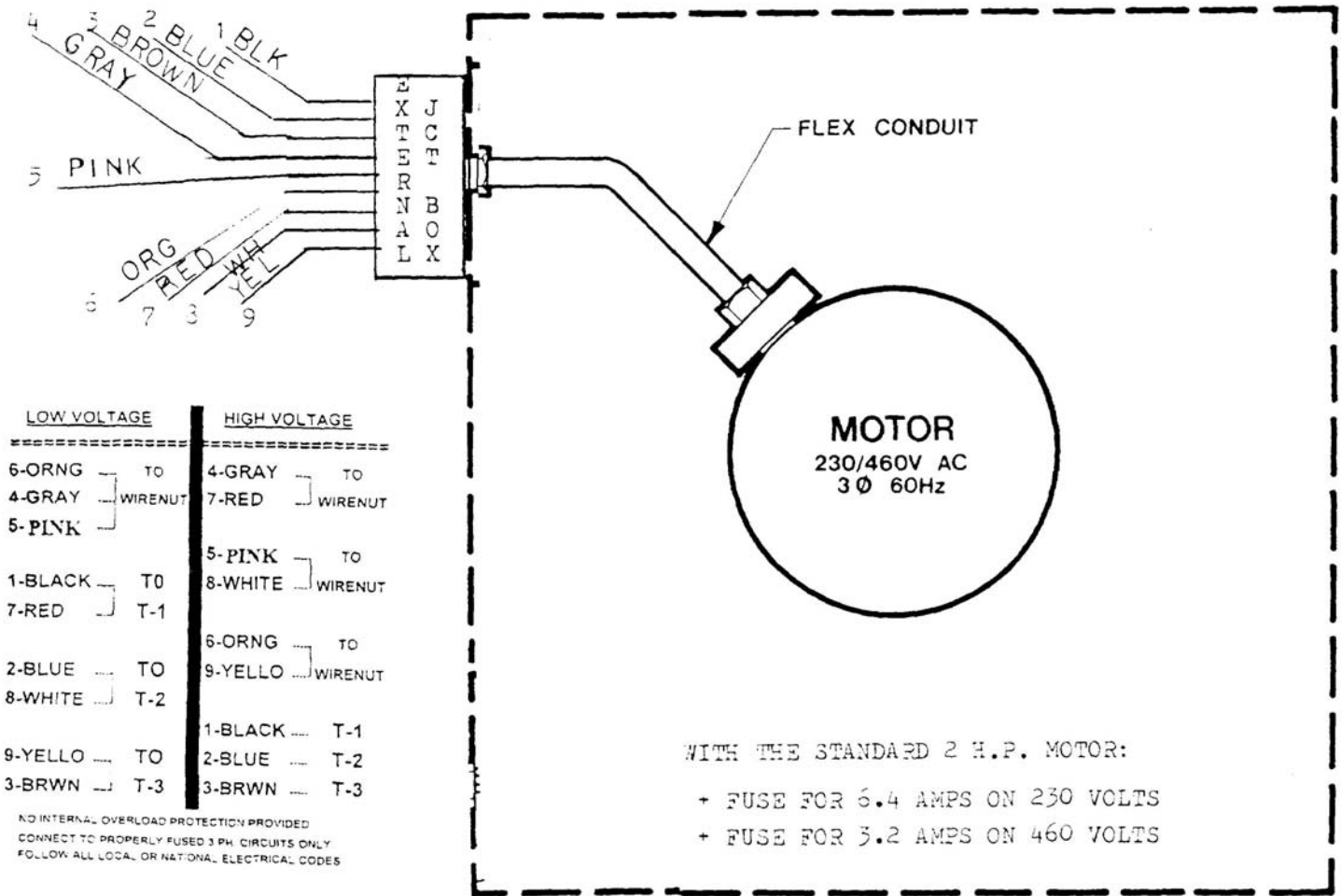

NOTES:

1. To reverse motor rotation, reverse any two (2) motor leads (L1,L2,L3).

Use a qualified electrical technician to create your electrical circuit, install your disconnect, and wire your motor junction box.

BLUE OX 4000 Series Parts List

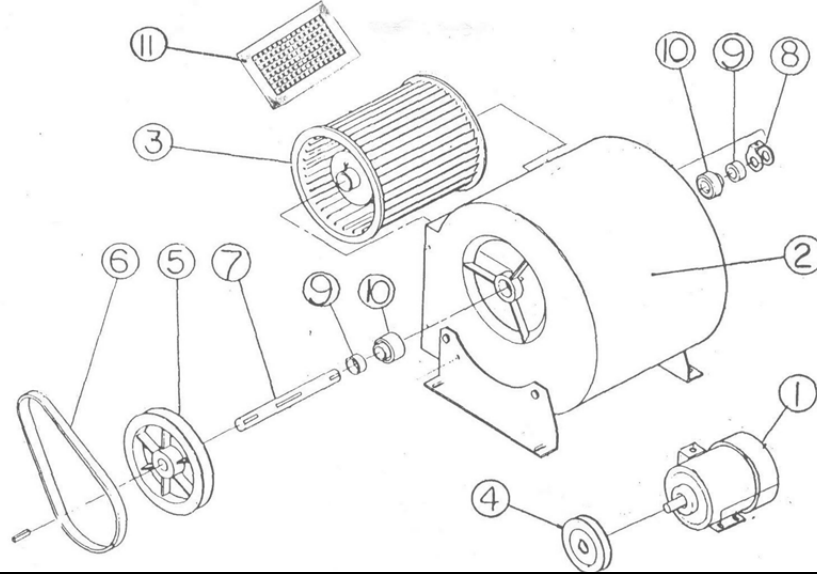

ITEM	PART #	DESCRIPTION
1	30C-3000	2 H.P. TEFCBB 3 Phase Motor
2	30C-3001	10" Complete Blower Assembly
3	30C-3002	Blower Wheel
4	30C-3003	Adjustable Motor Pulley
5	30C-3004	Blower Pulley
6	30C-3006	VEE Belt
7	30C-3007	Blower Shaft 3/4
8	30C-3008	Bearing Retainer
9	30C-3009	Neoprene Washer/Spacer
10	30C-3010	Ball Bearing with Neoprene Retainer
11	30C-3011	Louver 4-way Adjustable

OX4000 Replacement Filters

ITEM	PART #	DESCRIPTION
1	SP9508-4422	24" X 24" X 22" - 95% Bag Filter (8 Pocket)
2	SP9508M-4422	24" X 24" X 22" - 95% - Bag Filter for OIL MIST
3	SP6508-4422	24" X 24" X 22" - 65% Bag Filter (8 Pocket)
4	SP6508M-4422	24" X 24" X 22" - 65% - Bag Filter for OIL MIST
5	HE40-4404	4" Pleated Pre-Filter (Beverage Board Frame)
6	BOF-4404-AM	4" Washable Aluminum Mesh Pre-Filter

**ALWAYS USE BLUE OX REPLACEMENT FILTERS & PARTS TO MAINTAIN WARRANTY.
TO ORDER REPLACEMENT PARTS:**

AIR CLEANING SPECIALISTS, INC.
11088 Gravois Industrial Court, St. Louis, MO 63128
CALL 866-455-2135 | EMAIL info@aircleaningspecialists.com

Troubleshooting

Problem	Remedy
Motor starts with a whine and does not reach full speed.	If three-phase powered, stop motor immediately. It may be “single phasing” and will overheat, possibly damaging internal windings. Check fuses and/or wires for an interruption in one of the lines. The motor may be operating on two phases only.
Motor makes a scraping or knocking noise.	Check motor cooling fan and its cover. It may have been damaged or shifted in transit and motor fan is rubbing. Check for loose blower wheel on motor shaft – tighten if necessary.
No suction or pressure, or some suction but not as required (low or no airflow).	Check and open all dampers, if installed. Check ducting for blockage, if installed. Check for dirty or blocked filters (refer to Maintenance section). Check rotation of fan.
Excess vibration.	Check structural support members. Tighten all bolts on legs and cross braces. Make sure entire structure is solid. Check for loose blower wheel – tighten if necessary.
Contaminants blowing through unit.	Check for torn or damaged filters. Check filter seals. If carbon module is used, make sure filter sock in place. Check door seals.
Motor over-amping nameplate.	Access door open, close doors. Incorrect filters or no filters in the unit. Ductwork faulty.

If after performing the above TROUBLESHOOTING the unit fails to perform to specifications, contact:

Air Cleaning Specialists, Inc.

11088 Gravois Industrial Court - St. Louis, MO 63128

CALL 866-455-2135 | EMAIL info@aircleaningspecialists.com

Motor Trouble Guide

The purpose of this guide is to suggest common answers to electrical problems. The information is not all-inclusive and does not necessarily apply in all cases. When unusual operating conditions, repetitive failures, or other problems occur, consult an electric motor service firm for assistance.

Trouble	Cause – What To Do
Motor fails to start.	<p><u>Blown fuses</u> – Replace with time-delay fuses or circuit breakers. Check for grounded winding.</p> <p><u>Low voltage</u> – Use higher voltage tap on transformer terminals, increase wire size. Check for poor connections.</p> <p><u>Improper line connections</u> – Check connections against diagram supplied with motor.</p> <p><u>Overload tripped</u> – Check and reset relay in starter. Check heater rating against motor nameplate current rating. Check motor load. If the motor has manual re-set thermal protector, check if it has been tripped.</p> <p><u>Motor may be overloaded</u> – Reduce load. Increase motor size.</p> <p><u>If permanent split capacitor motor, capacitor may be open</u> – Indicated by humming sound. Replace run capacitor. See nameplate for correct value.</p> <p><u>Defective motor or starter</u> – Repair or replace.</p>
Motor stalls.	<p><u>Overloaded motor</u> – Reduce load or increase motor size.</p> <p><u>Low motor voltage</u> – See that nameplate voltage is maintained.</p>
Motor does not come up to speed.	<p><u>Not applied properly</u> – Consult motor service firm for proper type. Use larger motor.</p>
Motor takes too long to accelerate.	<p><u>Excess loading; high inertia load</u> – Reduce load. Increase motor size.</p> <p><u>Inadequate wiring</u> – Increase wire size. Check for poor connections.</p> <p><u>Applied voltage too low</u> – Reconnect to a</p>

	<p>higher transformer tap. Increase wire size. Check for poor connections.</p> <p><u>Defective motor</u> – Repair or replace.</p> <p><u>Inadequate starting torque</u> – Replace with higher horsepower motor.</p>
Motor vibrates or is excessively noisy.	<p><u>Motor misaligned</u> – Realign.</p> <p><u>High voltages</u> – Check wiring connections, transformer.</p> <p><u>Worn, damaged, dirty or overloaded bearings</u> – Replace, check loading and alignment.</p> <p><u>Loose or defective or out-of-balance air mover</u> – Tighten set screw(s), repair or replace.</p>
Insufficient speed change.	<p><u>Insufficient motor load</u> – Use a lower horsepower motor. Reduce system restrictions (blower). Increase system restriction (blower fan).</p>
Motor overheats while running under load.	<p><u>Overload</u> – Reduce load; increase motor size.</p> <p><u>Dirt preventing ventilation</u> – Clean motor.</p> <p><u>Faulty connection</u> – Clean, tighten or replace.</p> <p><u>High or low voltage</u> – Check voltage at motor; should not be more than 10% above or below rated.</p> <p><u>Defective motor</u> – Repair or replace.</p>

ALWAYS USE BLUE OX REPLACEMENT FILTERS & PARTS TO MAINTAIN WARRANTY. TO ORDER REPLACEMENT PARTS:

Air Cleaning Specialists, Inc.

11088 Gravois Industrial Court - St. Louis, MO 63128

CALL 866-455-2135 | EMAIL info@aircleaningspecialists.com