



# BLUE OX3500C

## 3000 CFM Media Filtration System With 2 HP TEFCBB



The BLUE OX3500C has been engineered using high quality products housed in a 16 gauge steel cabinet, finished in a blue chemical resistant polyurethane paint. The OX3500C air cleaning system unit has a number of distinct advantages over conventionally designed units. The dual set of filters provides more filter area and allows the unit to operate with considerably less static pressure. The lower air-flow-to-filter ratio provides higher efficiency and longer life. The OX3500C also comes with the option of adding an additional Wrap-A-Round Pre-filter, which extends the life of the main bag filter.

Applications	Features	Specifications
Welding Smoke / Fumes	"T" Pattern Airflow	Dimensions: 26" W 24" H 72" L
Grinding Dust	Easy Installation	Shipping Weight: 195 lbs.
Bondo Dust	High Efficiency	Hanging Weight: 270 lbs.
Diesel Smoke	4-Way Louvers	Input Power: 220/440 Volt 3 Phase
Oil Mist	Long Filter Life	Power Consumed: 2540 Watts
Printing Powder	Low Operating Costs	Maximum Capacity: 3500 CFM
Plastic Dust	High Volume	Motor: 2 HP TEFCBB
Other Smoke / Dust	Easy Maintenance	Cabinet: 16 Gauge Steel
	16 Gauge Cabinet	Finish: "Circuit Blue" Chemical Resistant Polyurethane
	Noise Reduction	Speeds: Single Adjustable Pulley
	Low Initial Price	Filters: 65% (Included) to 95%
	Washable Pre-filters	Blower: Centrifugal type

### How the OX3500C Works

A large centrifugal type blower draws the contaminated air from the room through a set of highly efficient micro-glass filters that separate the sub-micron particles from the air stream. The cleaned air is then discharged back into the room for reuse. No ductwork is required, and there is no loss of heat or air conditioning. Optional charcoal filters are available for odor control and a HEPA type filter is available for those areas which demand the ultimate in clean air.

### Installation

Installation of your new OX3500C may be accomplished in a variety of ways. The OX3500C is designed for chain-hanging, rod-mounting, or a wall bracket installation to suit your individual application. The OX3500C operates on 220/440 Volts, 3 phase and includes a pre-wired junction box.

### Standard OX3500C Unit Includes:

Two 24 x 24 x 4" Pleated Pre-Filter  
Two 24 x 24 x 22" 65% 8 Pocket Bag Filter

### Additional Unit Options:

OX3500C-WA: Standard plus 2 **Wrap-A-Round** Fiber Prefilter Cages with hinges mounted on Front or Back. Media is 25 x 60 x 2". Unit = 108" Long.  
OX3500C-CF Standard plus 2 Charcoal Afterfilters 50% Bypass

### Additional Filter Options:

24 x 24 x 22" 95% 8 Pocket Bag Filter (Replaces 65% Bag)  
24 x 24 x 4" Alum Mesh Pre-Filter (Replaces One Pleated)

### Cabinet Options

Silencer: Reduces noise by 6 - 8 Decibels  
L Brackets: OX3500C Mounting Brackets (set of 2)

**Eyebolts: Eyebolts Installed**

Mounting Kit: Chain & Eyebolts

Spray Can: Touch-up Paint (Circuit Blue)

Pressure Gauge: Magnetic Pressure Gauge

Optional 3 HP TEFCBB

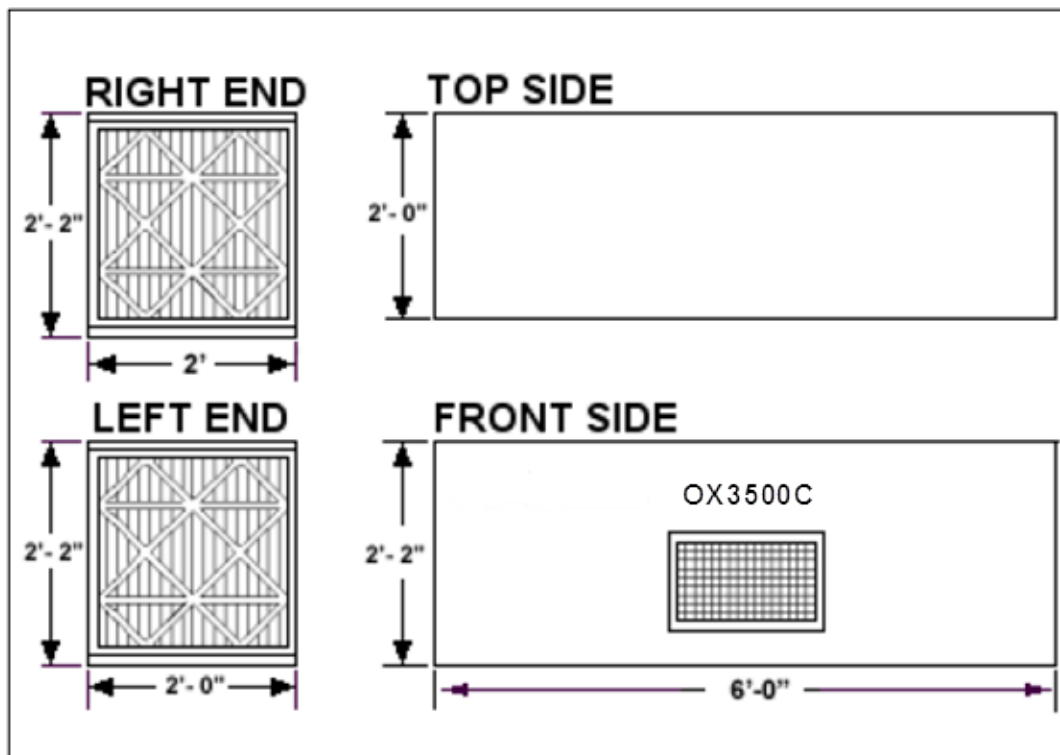

**FOR INQUIRIES AND SALES INFORMATION CONTACT:**

**AIR CLEANING SPECIALISTS, INC.**

826 Horan Drive, Fenton, MO 63026

CALL 866-455-2135 | EMAIL [info@aircleaningspecialists.com](mailto:info@aircleaningspecialists.com)